

Optical bus extender according to the ISO-9141 standard OBE9141



The OBE9141 system allows the connection, by means of optical fibers, between an Electronic Control Unit (ECU) on a vehicle and a Diagnostic Tester (DT), according to the ISO-9141 standard.

The system is composed by an optical transceiver (OBE9141 ECU) interfacing the ECU, placed on the vehicle or near it in the test area and another optical transceiver (OBE9141 DT) interfacing the DT, typically outside the high field test area. The two transducers, both shielded up to 200 V/m over the bandwidth from 10kHz to 18GHz, are connected via three optical fiber cables.

With three optical fibers the system allows all the communication types described by the standard; for some of the height possible configurations only one or two fibers are needed.

The two transducers are similar but not identical.

The OBE9141ECU is powered from the ECU or the vehicle, the OBE9141DT has a dedicated power supply and provides power to the attached DT equipment.

THE ISO-9141 STANDARD

The ISO-9141 standard specifies the requirements for setting up the interchange of digital information between an on board ECU and a suitable diagnostic tester. This communication is established in order to facilitate inspection, test, diagnosis and adjustment of vehicles, systems and ECU's.

The ECU shall have one (K) or two (L and K) communication connections.

If lines K or L from one or more ECU's are connected together the resulting system is called a bus system.

Line K is defined as the line which provides information in a serial digital form from the ECU to the diagnostic tester, Line K may also be used bidirectional, in which case it may carry commands or data from the diagnostic tester to the ECU. Moreover line K may be used to initialize the serial communication. Line L is a unidirectional line from the diagnostic tester to the ECU. When it exists it may be used to initialize the serial communication and/or to carry commands and/or data.

POSSIBLE CONFIGURATIONS

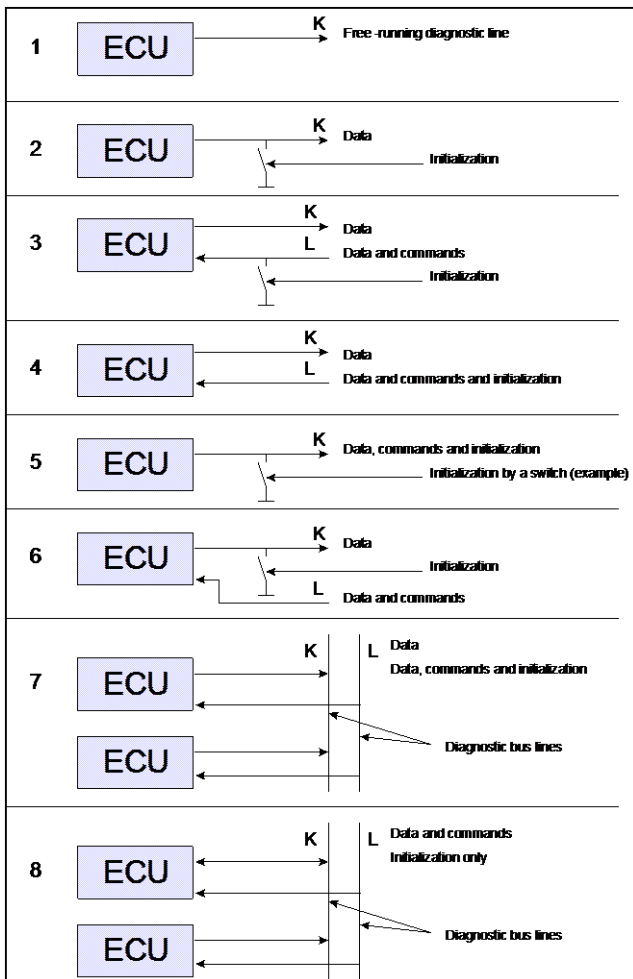

TECHNICAL CHARACTERISTICS

Battery voltage (nominal)	12V
Input threshold high	$2/3 * V_b \pm 10\%$
Input threshold low	$1/3 * V_b \pm 10\%$
Output resistance "OFF"	$500\Omega \pm 5\%$
Output resistance "ON"	$<20\Omega$
Input resistance "OFF"	$>10K\Omega$
Baud rate	>100 k bits
Optical connectors	ST
Optical fibers cable	200/230 μ m
Electrical interface connectors	D 9 pole female filtered
Power supply connector (For DT only) circular	LEMO 5 poles circular

SYSTEM PARTS

OBE9141ECU	Electronic control unit interface
OBE9141DT	Diagnostic Tester interface
AL2 (*)	External power supply DC 12V 0.5A 230V-50Hz for OBE9141DT
FBmmm	Bifiber optical cable (mmm=length in m)
FCmmm	Monofiber optical cable (mmm=length in m)

24V OPTION

OBE9141ECU/24	Electronic control unit 24V (It replaces OBE9141ECU)
AL2/24	(*)External power supply DC 24V 0.5A 230V - 50Hz (For OBE9141DT)

NOTE: OBE9141DT and fiber cables are the same for 12V or 24V applications.

(*) The 110VAC 60Hz version with the US power cord is available and identified by the suffix /US (for example: AL2/24/US)

FULL CONFIGURATION SYSTEM (3 fiber cables)

